



# TECHNICAL SHEET



Cod.: MP.0.168 US  
Rev.: 0



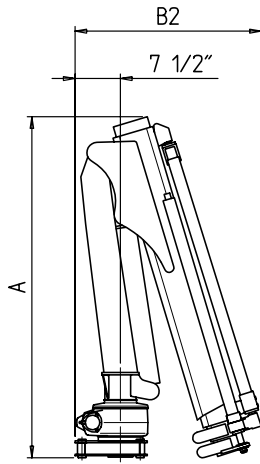
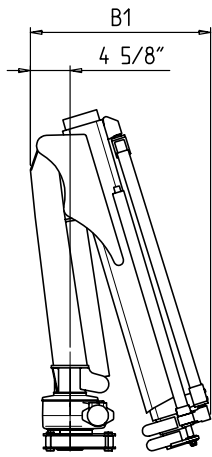

DIMENSIONS			
CRANE	A	B1	B2
ML 270.2	56"	31"	32"
ML 270.3	57"	31"	32"
ML 270L.2	59 1/2"	44 1/2"	45 1/2"
ML 270L.3	60"	47 1/4"	48"

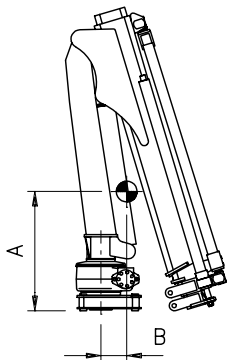
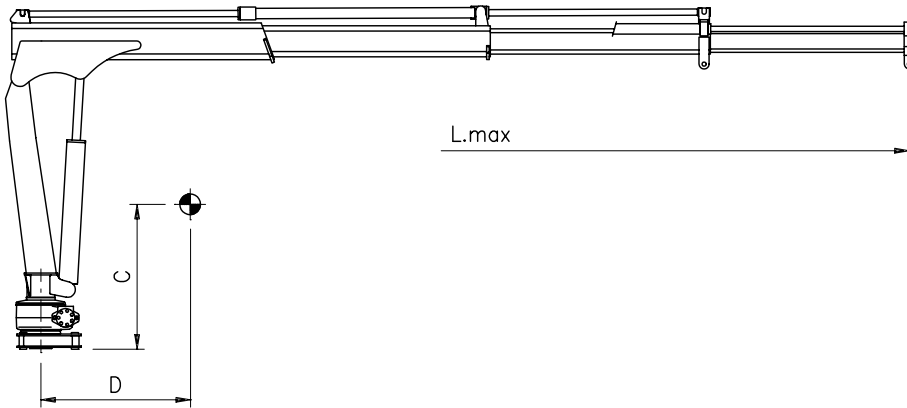
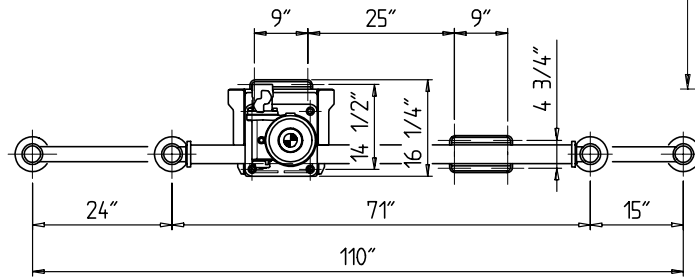
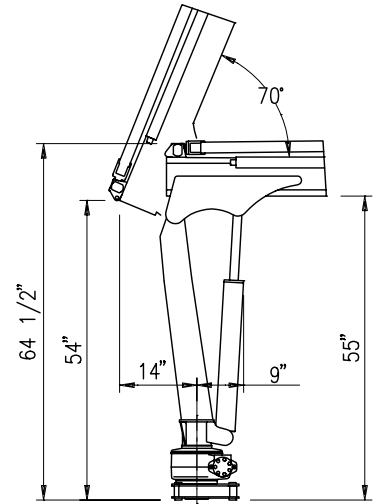
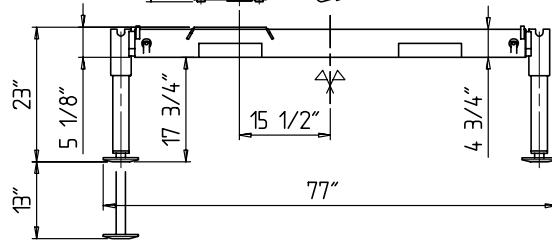
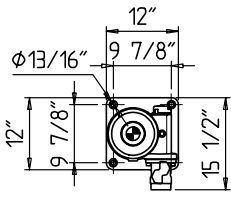

CRANE	A	B	C	D	L max
ML 270.2	20 7/8"	5 1/8"	33 7/8"	24 1/4"	126"
ML 270.3	21 1/4"	6"	37"	37"	165"
ML 270L.2	22 1/2"	8 3/4"	34 3/4"	30 1/2"	150"
ML 270L.3	23 1/4"	10 1/4"	38 1/4"	46"	197"

TECHNICAL DATA	U.M.	VERSION				
		ML 270.2	ML 270.3	ML 270L.2	ML 270L.3	
CRANE RATING	ft lbs	18500				
STANDARD EXTENSIONS Nr (HYDRAULICS)	N°	2H	3H	2H	3H	
STANDARD OUTREACH	ft	10' 6"	13' 9"	12' 5"	16' 5"	
SLEWING ANGLE	°	360°				
MAXIMUM ANGLE SLOPE	°	5°				
SLEWING TORQUE	ft lbs	2580				
MAX. LIFTING HEIGHT FROM CRANE BASE	ft	14' 1"	17'	15' 9"	19' 4"	
SUGGESTED OIL FLOW	gpm	2.6÷3.2				
MAX. WORKING PRESSURE	p.s.i.	3190				
BASIC CRANE WEIGHT	lbs	VERS. H	495	560	520	595
		VERS. E	540	605	560	640
BASE WEIGHT WITH EXTENDABLE STABILIZERS	lbs	225÷240				
BEAM WEIGHT WITH 2 EXTENDABLE STABILIZERS	lbs	150÷180				
MOTOR ABSORPTION FOR ELECTROHYDR. CRANE 12V	A min/max	80/240	80/240	80/240	80/240	
MOTOR ABSORPTION FOR ELECTROHYDR. CRANE 24V	A min/max	50/150	50/150	50/150	50/150	

WINCH SPECIFICATIONS	U.M.	
MAX. WINCH SINGLE LINE CAPACITY (3 <sup>rd</sup> LAYER)	lbs	1540
ROPE DIAMETER	inches	9/32"
ROPE LENGTH	ft	82
WINCH KIT WEIGHT	lbs	155

VERSION	DESCRIPTION
"E" 12V	ELECTROHYDRAULIC
"E" 24V	ELECTROHYDRAULIC
"H"	HYDRAULIC

OPERATING TIMES												
VERS.	SLEW. (rpm)	LIFT. (sec)		LOWERING (sec)	EXTENSION OUT (sec)				EXTENSION IN (sec)			
		p min	p max		270.2	270.3	270L.2	270L.3	270.2	270.3	270L.2	270L.3
"E" 12/24V	2.4	17	30	16	16	23	19	28	8	13	9	15
"H" (PTO)	2.7	17		16	16	23	19	28	8	13	9	15

p min: min. working pressure  
p max: max. working pressure

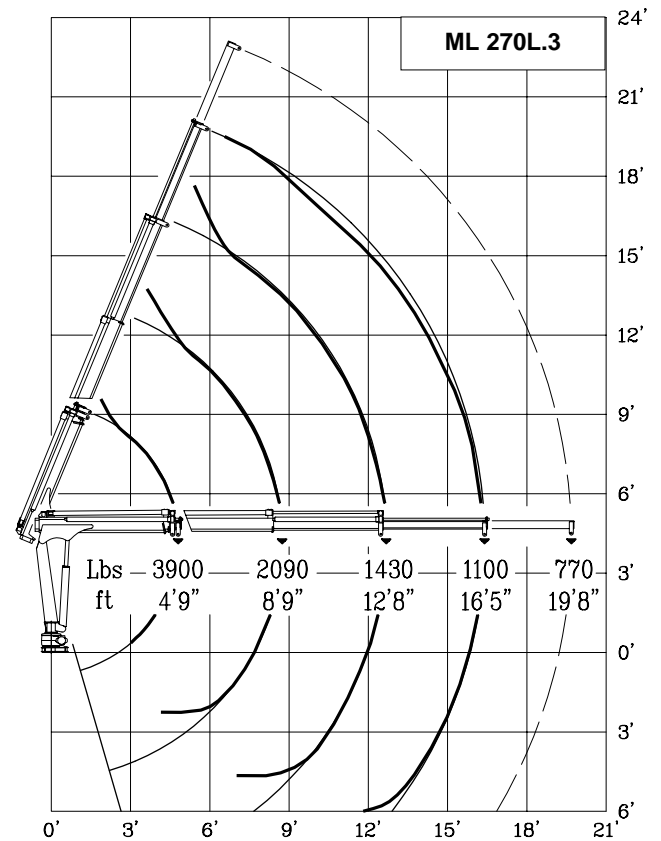
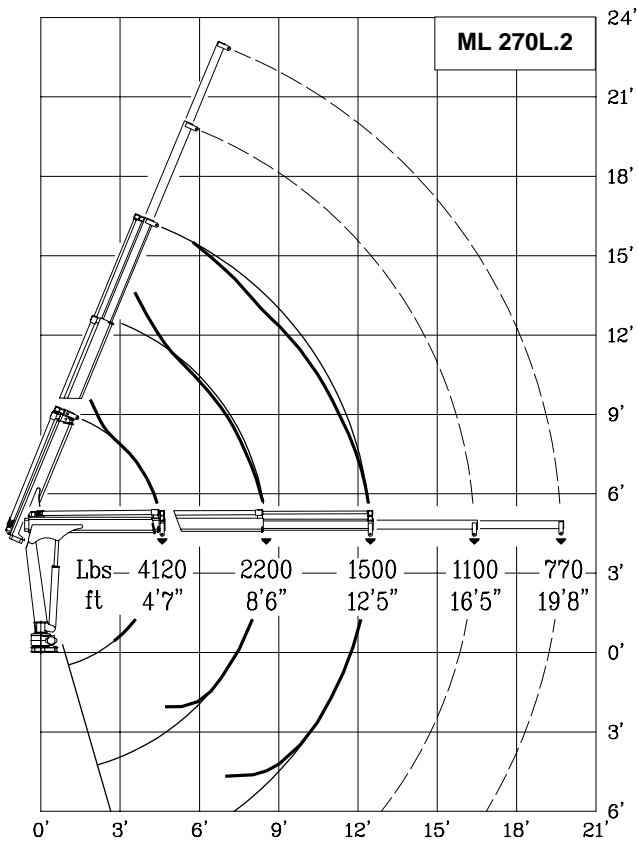
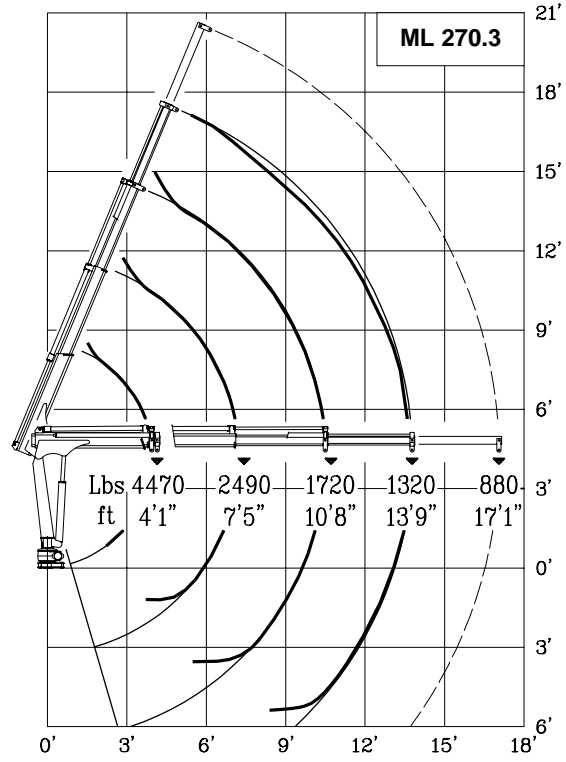
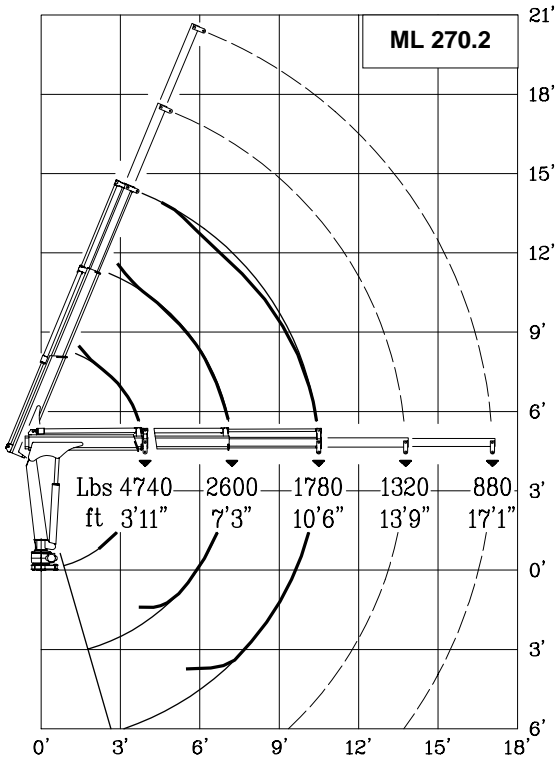

Lifting class **HC1 – HD4/B2**