

OTR TIRE SERVICE CRANES



STS SERIES
AMKO 

OTR TIRE SERVICE CRANES



**TECHNO
& CRANE** Inc
Big on Small Cranes

T: 604-575-2103 / [1-877-531-8644](tel:1-877-531-8644) ♦ F: 604-575-2105
#403, 17665 – 66A Avenue Surrey, BC Canada V3S 2A7
E-mail: sales@technocrane.ca ♦ www.technocrane.ca



STS SERIES

AMK

50 STS • 70 STS • 110 STS • 250 STS

SPECIAL TIRE SERVICE CRANES



Minimum truck: G.V.W.

11,000 lbs (50 STS)

22,000 lbs (70 STS)

26,000 lbs (110 STS)

33,000 lbs (250 STS)

50 STS

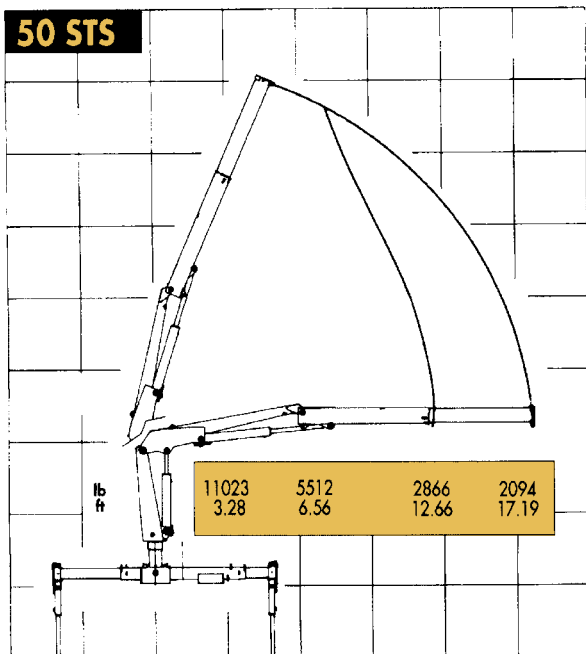

70 STS

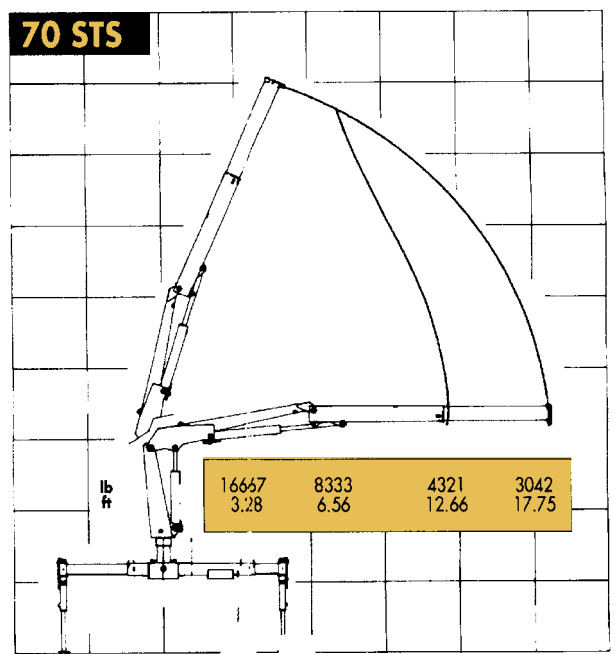

Features

- Manufactured by ISO9001 company certified by DNV.
- Manufactured from fine-grained high-tensile steel.
 - more strength, less weight.
- Boom is hexagonal in shape.
- Extension cylinder is enclosed and protected inside boom.
- Column is mounted toward centre of chassis.
 - better stability.
 - crane can work well from both sides.
- Rack and pinion rotation system.
 - simple, low maintenance, easy to service.
- Choice of controls available.
 - manual, dual side control.
 - wired remote.
 - radio remote.
- Independent side adjustable outrigger stabilizers.
- Flange mounted safety valves on all lifting cylinders.
- Safety lock valves on stabilizers.



FLANGED SAFETY VALVES



HEXAGONAL BOOM



ENCLOSED CYLINDER



RADIO CONTROL

MODEL	LIFTING MOMENT	HORIZONTAL EXTENSION	LIFTING @ MAX. REACH	SLEWING ANGLE	WEIGHT
	Ft. Lbs	Ft	Lbs	°	Lbs
50 STS	36200	17.18	2095	380	1675
70 STS	54700	17.75	3045	370	2215
110 STS	75600	18.37	4100	370	2935
250 STS	180800	18.70	9460	400	6415

110 STS

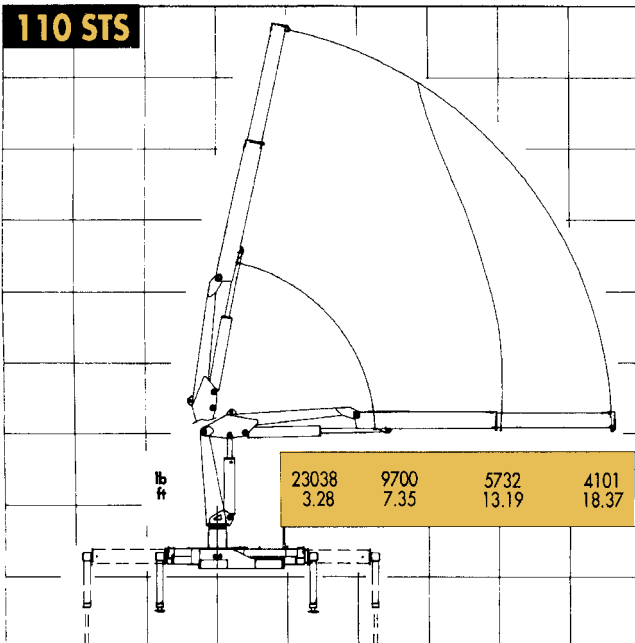

250 STS

