

DATI TECNICI TECHNICAL DATA

MOD.	817/1S	817/2S	817/3S	817/4S	817/5S	817/6S
A	2165	2275	2370	2440	2495	2495
B	2295	2295	2295	2295	2295	2295
C	1244	1244	1244	1244	1244	1244
D	624	624	624	624	624	624
E	150	150	150	150	150	150
F	2300	2300	2300	2300	2300	2300
G	1600	1600	1600	1600	1600	1600
H	5500	5500	5500	5500	5500	5500
I	420	420	420	420	420	420
L	970	970	1000	1000	1000	1000
M	1100	1100	1100	1100	1100	1100

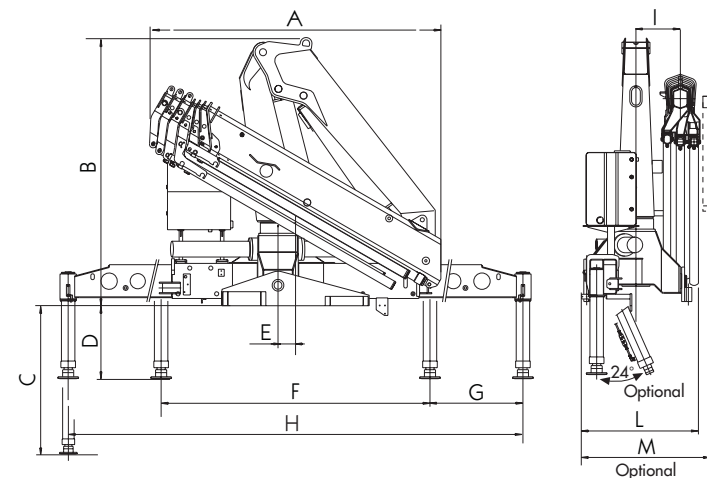

MOMENTO DI SOLLEVAMENTO
MAX. LIFTING MOMENT
MOMENT D'ELEVATION MAX.
MAX. AUFHEBEMOMENT
MOMENTOS DE ELEVACION
MOMENTO DE ELEVACAO MAX.
(t.m.)

817
18,8

SBRACCIO MAX. VERTICALE
MAX VERTICAL REACH
LONGEUR DU BRAS VERTICALE
MAX VERTIKAL REICHWEITE
ALCANCE MAX. VERTICAL
ALCANCE MAX. VERTICAL
(m.)

817 1S 2S 3S 4S 5S 6S
hyd. 9,9 11,8 13,8 15,7 17,8 19,8
man. - - 19,8 22,0 22,0 22,0

ANGOLO DI ROTAZIONE
SLEWING ANGLE
ANGLE ROTATION
SCHWENKBEREICH
ANGULO DE ROTACION
ANGULO DE ROTACAO
(°)

817
410°

VELOCITÀ DI ROTAZIONE
SLEWING SPEED
VITESSE DE ROTATION
DREHGESCHWINDIGKEIT
VELOCIDAD DE ROTACION
VELOCIDADE DE RUTACAO
(180°)

817
17s

PENDENZA MAX. DI LAVORO
MAX WORKING HEEL
DEVERS MAXI DE TRAVAIL
MAX. ARBEITSEINIGUNG
INCLINACION MÁX. DE TRABAJO
PENDENCIA MÁX. DE TRABALHO
(°)

817
5°

PRESSIONE D'ESERCIZIO
WORKING PRESSURE
PRESSION DE SERVICE
BETRIEBSDRUCK
PRESIÓN DE TRABAJO
PRESSAO DE TRABALHO
(bar)

817
310

PESO GRU SENZA STABILIZZATORI
CRANE WEIGHT WITHOUT STABILIZER
MASSE GRUE SANS STABILISATEURS
KRANGEWICHT OHNE ABSTÜTZUNGEN
PESO DE LA GRUA SIN GATOS
PESO DA GRUA SEM ESTABILIZADORE
(kg.)

817 1S 2S 3S 4S 5S 6S
1770 1910 2030 2150 2250 2340

PESO STABILIZZATORI
WEIGHT OF STABILIZERS
POIDS DES STABILISATEURS
GEWICHT DER ABSTÜTZUNGEN
PESO GATOS EXTENSIBLES
PESO DOS ESTABILIZADORES
(kg.)

817
360

CAPACITÀ SERBATOIO OLIO
OIL TANK CAPACITY
CONTENANCE RÉSERVOIR HUILE
ÖLBEHALTERHINHALT
CAPACIDAD DEL DEPÓSITO ACEITE
CAPACIDADE DO DEPOSITO DE OLEO
(l.)

817
130

PORTATA AL DISTRIBUTORE
OIL HYDRAULIC DISCHARGE TO THE DISTRIBUTOR BOX
DÉBIT D'UILE HYDRAULIQUE AU DISTRIBUTEUR
HYDRAULISCHE ÖL TRAGFÄHIGKEIT ZUM STEUERUNG
CAUDAL AL DISTRIBUIDOR
DESCARGA DE OLEO HIDRAULICO AO DISTRIBUIDOR
(l/min.)

817
32

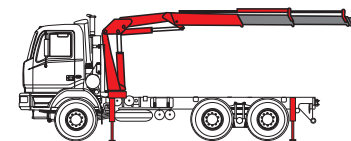

Autocarro consigliato
Recommended truck
Camion conseillé
Camion aconsejado
Camiao aconselhado
Passo - Wheelbase - Empattement - Passo: 3700 mm. M.T.T. ton 15
G.V.W. ton 15

ACCESSORI

- Prolonghe meccaniche
- Stabilizzatori girevoli
- Attivazione elementi supplementari
- Posto di manovra in alto
- Verricello
- Comando a distanza

ACCESSORIES

- Manual extensions
- Turning stabilizers
- Supplementary element activation
- Top seat
- Winch
- Remote control

ACCESSOIRES

- Rallonges mécaniques
- Stabilisateurs pivotants
- Activation élément supplémentaires
- Siège en haut
- Treuil
- Commande à distance

ZUBEHOERE

- Manuelle Verlängerungen
- Schwenkbare Abstützbeine
- Zusatzfunktionen für Zange, Dreh servo,
- Hochsitz
- Winde
- Fernsteuerung

ACCESORIOS

- Prolongaciones mecánicas
- Gatos giratorios
- Activación elementos suplementarios
- Puesto de maniobra arriba
- Cabrestante
- Mando a distancia

ACCESORIOS

- Prolongaciones mecánicas
- Estabilizadores giratorios
- Activacao de elementos suplementares
- Posto de manobra no cimo
- Guincho
- Comando a distancia

Dati, descrizioni e illustrazioni sono indicativi e non impegnano Amco Veba. Gru prodotte e/o commercializzate da Amco Veba - Data, descriptions and illustrations are merely indicative and not binding. Cranes manufactured and marketed by Amco Veba - Les données, descriptions et illustrations sont uniquement indicatives et n'engagent pas Amco Veba. Grues produites et/ou vendues par Amco Veba - Angaben, Beschreibungen und Abbildungen sind weisend und verpflichten nicht Amco Veba. Die Kräne werden von Amco Veba hergestellt und/oder vermarktet - Los datos, las descripciones y las ilustraciones son indicativos y no implican compromiso para Amco Veba. Gruas producidas y/o comercializadas por Amco Veba - Os dados as descrições e ilustrações são indicativos e não comprometem Amco Veba. Guindaste produzidos e/ou comercializados pela Amco Veba.

AMCO VEB
GROUP

817

Amco Veba s.r.l.
Via Einstein, 4
42028 Poggio (RE) Italy
Tel. ++39 0522 40.80.11
Fax ++39 0522 40.80.80
E-mail: commerciale@amcoveba.it
www.amcoveba.com

COMPANY
WITH QUALITY SYSTEM
CERTIFIED BY DNV
=ISO 9001/2000=



817



AMCO VEB
GROUP



- Limitatore di momento
- Comandi bilaterali
- Sfilii esagonali
- Mart. sfilo indipendenti
- Mart. stab. fissi
- Stabilizzatori allargabili idraulicamente
- Valvole flangiate
- Serbatoio olio
- Kit di montaggio
- Norma di progettazione: EN12999
- Classe di collaudo a fatica: B3
- Sprint Generation System (S.G.S.)



- Load limiting device
- Dual controls
- Hexagonal section extension
- Independent extension cylinders
- Fixed stabilizer cylinders
- Outriggers with hydraulic extension
- Flanged valves
- Oil tank
- Assembly kit
- Design in accordance with EN12999
- Fatigue test classification: B3
- Sprint Generation System (S.G.S.)



- Limiteur de moment
- Commandes bilatérales
- Extensions hydrauliques à section hexagonale
- Vérins hydrauliques à sortie indépendante
- Béquilles fixes
- Béquilles avec ouverture hydraulique
- Vannes bridées
- Réservoir pour huile
- Kit de brides de fixation
- Projée e en accords aux normes: EN 12999
- Essai de fatigue avec classification: B3
- Sprint Generation System (S.G.S.)



- Momentbegrenzer
- Beiseitige Kransteuerung
- Sechskantige Auszüge
- Unabhängige Auszugszylinder
- Fixed Zylinder
- Seitlich hydraulisch ausfahrbare Abstützungsbaine
- Ventile mit Flansch
- Ölbehälter
- Montagesatz
- Berechnungsnorm nach EN12999
- Ermüdungstest in Klasse: B3
- Sprint Generation System (S.G.S.)



- Limitador de momento
- Mandos bilaterales
- Brazos telescópicos hexagonales
- Cilindros extensión independientes
- Gatos estabilizadores fijos
- Estabilizadores extraíbles hidráulicamente
- Valvulas pilotadas
- Deposito aceite
- Kit de ensanblaje
- Norma del proyecto: EN12999
- Tipo de ensayo a la fatiga: B3
- Sprint Generation System (S.G.S.)



- Limitador de momento
- Comandos bilaterales
- Extensoes hexagonais
- Cilindros de extensao independentes
- Gatos estabilizadores fijos
- Estabilizador alongadohidráulicamente
- Válvulas de segurança
- Deposito de óleo
- Kit de montagem
- Norma de protecao EN12999
- Typo de Ensayo a la fatiga: B3
- Sprint Generation System (S.G.S.)

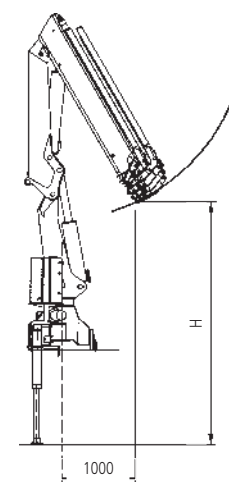
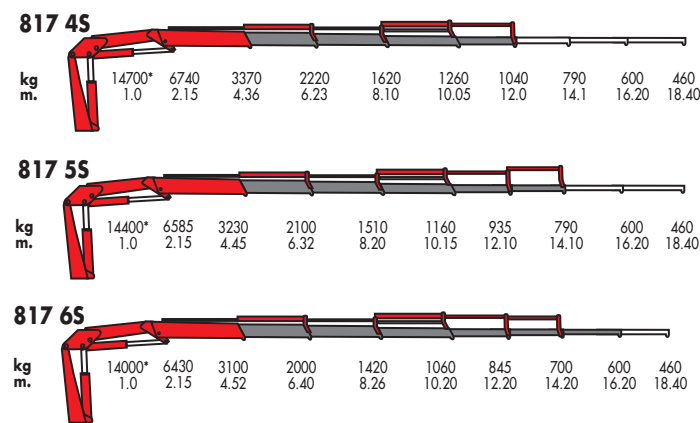
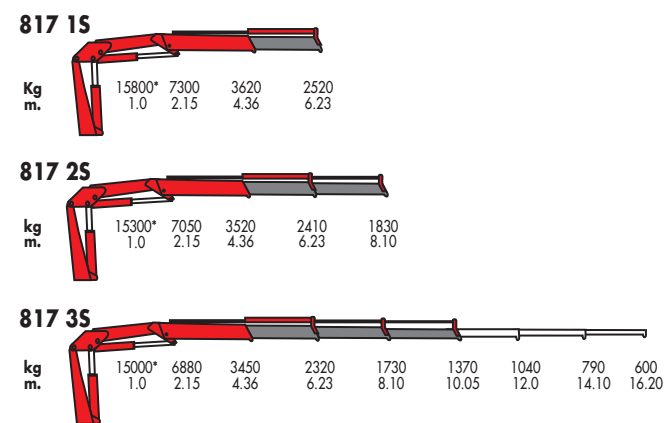

- H 817/1S = 3600**
- H 817/2S = 3550**
- H 817/3S = 3500**
- H 817/4S = 3500**
- H 817/5S = 3430**
- H 817/6S = 3370**

(*) Portata teorica Theoretical lifting capacity

